



TALKAPHONE

DOOR ENTRY & GATE CONTROL

# VOIP-200 SERIES COMPACT IP CALL STATION SYSTEM



WE'VE UNLOCKED THE POTENTIAL OF EMERGENCY COMMUNICATIONS.

WE'RE OPENING NEW DOORS WITH OPTIONAL SEAMLESS INTEGRATION BETWEEN CALL STATION AND ATTENDANT PHONE.

### IP VIDEO ATTENDANT PHONE (GRANDSTREAM)

- Unit receives a basic pre-program to integrate easily with Talkaphone VOIP-200 series and includes technical support
- Basic telephony features include: hold, transfer, call waiting, and call history
- Advanced telephony features (requires SIP-based PBX) include: forward, call park/pickup, 6-way audio conferencing, shared-call-appearance (SCA)/bridged-line-appearance (BLA), virtual MPK, boss-secretary virtual button, hot desking, flexible dial plan, and server redundancy & failover
- Supports up to (100) VOIP-200 Series IP Call Stations

### WAVESENSE TECHNOLOGY FOR CONTACTLESS CALL FOR ASSISTANCE

NEW

- WaveSense Technology enables contactless call for assistance
- Provides visitors and staff a contactless, hygienic method (through deliberate gestures) to initiate communication to request door access

### COMPACT IP CALL STATION

- Exceptional sound clarity during conversation (over 85dB, configurable)
- Additional Ethernet port to connect other devices
- Supports standard Session Initiation Protocol (SIP), RFC 3261
- Remote software upgrade, configuration, and monitoring
- Power over Ethernet (PoE, 802.3af), local 19-27 VDC
- IP66 vandal resistant marine grade stainless steel faceplate
- LED indicator for the hearing impaired
- Built-in auto-dialer can dial up to six numbers: if first number doesn't answer or is busy, dials next number
- Available in a variety of languages
- Compatible with Avaya Aura®, Avaya IP Office™, and Cisco Unified Communications Manager (Unified CM)



### IP VIDEO DOOR ENTRY STATION

All of the features of the Compact IP Call Station plus:

- ONVIF compliant wide-angle megapixel IP camera
- Dual-stream video at different frame rate and bandwidth
- Camera interoperates with a variety of VMS platforms and Model AVM-1 (not compatible with third-party video phones)

Note: All prices and specifications are subject to change without notice. Talk-A-Phone, Talkaphone, Scream Alert, WEBS, and WEBS Contact are registered trademarks of Talk-A-Phone, LLC.

All rights reserved. All other trademarks mentioned in this document or website are the property of their respective owners and does not imply or indicate any approval, endorsement, sponsorship, or affiliation with such owners unless such approval, endorsement, sponsorship, or affiliation is expressly indicated.

## APPLICATIONS



### Existing Installations

Add either a flush mounted or surface mounted WaveSense to an existing IP Call Station. \*

- Deliberate gesture at the WaveSense unit triggers the IP Call Station to place a call
- Audio and/or video (if available) provided by the IP Call Station to validate entry
- Send DTMF remotely to output dry contact from IP Call Station to access control system

\* For more information, see WaveSense datasheet.

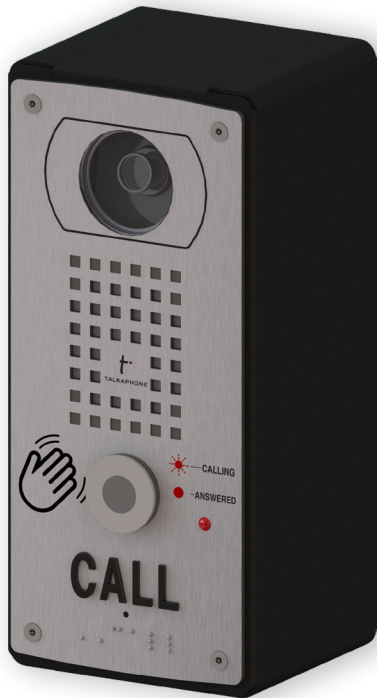

### New Installations

VOIP-200 Series IP Call Station available with built-in WaveSense technology.

- Deliberate gesture at the WaveSense-enabled IP Call Station triggers a call to be placed
- Audio and/or video (if available) provided by the IP Call Station to validate entry
- Send DTMF remotely to output dry contact from IP Call Station to access control system

## APPLICATIONS

Applying WaveSense technology with Call Stations helps to reduce bacterial and viral spread in high traffic applications such as:

- Schools
- Daycare facilities
- Commercial and office real estate
- Healthcare facilities (e.g., clinics, pharmacies, etc.)
- Parking facilities (e.g., garages, parking lots, etc.)

**Schools**



**Daycare Facilities**



**Healthcare Facilities**



**Commercial & Office**



**Parking Facilities**



*Any application where a call station would be installed.*



# SPECIFICATIONS



## VOIP-200 Series

General Specifications	
Construction:	0.09" (2.2mm), #4 brushed 316 stainless steel faceplate
Operating Temperature:	-40°F to +158°F (-40°C to +70°C)
Relative Humidity:	Up to 95% non-condensing
Protection:	IP66, vandal-resistant and water-resistant design
Communication:	Full duplex, two-way hands-free communication
Call Control Signaling:	SIP (RFC 3261 compliant), SIP INFO (DTMF), RFC 2833 (DTMF)
Power:	Power over Ethernet, IEEE 802.3af, Class 0 Local power 19-27 VDC, Idle 4W, Max. 8W
Auxiliary Contact:	One (1) Aux Output, dry contact Max Switching Current: 1.0A Max Switching Voltage: 125VAC, 60VDC Max Switching Power: 62.5VA, 30W Rated Load: 0.5A at 125VAC, 1.0A at 24VDC
Network:	10/100 BaseTX Ethernet, RJ45 connectors, Cat5e or better
IP Protocols:	IPv4, TCP, UDP, HTTPS, TFTP, RTP, RTCP, DHCP, SIP, SNMP
LAN Protocols:	Power over Ethernet (IEEE 802.3af), VLAN (IEEE 802.1 pq), Network Access Control (IEEE 802.1 x), STP (IEEE 802.1 d), RSTP (IEEE 802.1 d-2004)
Programming:	Non-volatile flash memory programming and configuration through Web GUI
Management and Operation:	HTTPS (Web configuration), DHCP and static IP, remote automatic software upgrade, centralized monitoring, status LED
Audio Codecs:	G.711, G.722, G.729
Approvals:	ETL Listed -- Conforms to ANSI/UL Standards 60950-1 and 60950-22. Certified to CAN/CSA Standard C22.2 Nos. 60950-1 and 60950-22.  Note: Models configured with built-in WaveSense sensor are not ETL Listed.
Warranty:	2-year limited warranty

All specifications are subject to change without notice.

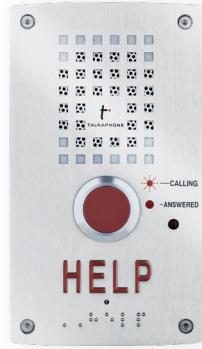

# SPECIFICATIONS

		Compact IP Call Station	Compact IP Help Station
			
<b>Model:</b>	<b>VOIP-200C:</b> Flush mount configuration	<b>VOIP-200H:</b> Flush mount configuration	
<b>Dimensions (W x H x D):</b>	3.7 x 6.38 x 2.38 in. (94 x 162 x 60 mm)	3.7 x 6.38 x 2.38 in. (94 x 162 x 60 mm)	
<b>Dimensions After Flush Mount (W x H x D):</b>	3.7 x 6.38 x 0.4 in. (94 x 162 x 10 mm)	3.7 x 6.38 x 0.4 in. (94 x 162 x 10 mm)	
<b>Model:</b>	<b>VOIP-201C:</b> Surface mount configuration	<b>VOIP-201H:</b> Surface mount configuration	
<b>Dimensions (W x H x D):</b>	4.0 x 6.75 x 2.63 in. (101 x 171 x 66 mm)	4.0 x 6.75 x 2.63 in. (101 x 171 x 66 mm)	
<b>Weight:</b>	2.2 lbs. (1.0 kg)	2.2 lbs. (1.0 kg)	
		IP Video Call Station	IP Video Help Station
			
<b>Model:</b>	<b>VOIP-200C3:</b> Flush mount configuration	<b>VOIP-200H3:</b> Flush mount configuration	
<b>Dimensions (W x H x D):</b>	4.0 x 8.39 x 3.1 in. (101 x 213 x 76 mm)	4.0 x 8.39 x 3.1 in. (101 x 213 x 76 mm)	
<b>Dimensions After Flush Mount (W x H x D):</b>	4.0 x 8.39 x 0.4 in. (101 x 213 x 10 mm)	4.0 x 8.39 x 0.4 in. (101 x 213 x 10 mm)	
<b>Model:</b>	<b>VOIP-201C3:</b> Surface mount configuration	<b>VOIP-201H3:</b> Surface mount configuration	
<b>Dimensions (W x H x D):</b>	4.0 x 8.75 x 3.1 in. (101 x 222 x 76 mm)	4.0 x 8.75 x 3.1 in. (101 x 222 x 76 mm)	
<b>Weight</b>	2.8 lbs. (1.3kg)	2.8 lbs. (1.3kg)	
<b>Camera</b>	<b>Image Sensor:</b>	2.43 Megapixel, 1/2.8" SONY Exmor CMOS	2.43 Megapixel, 1/2.8" SONY Exmor CMOS
	<b>Total Pixels:</b>	2000 x 1241	2000 x 1241
	<b>Min. Illumination:</b>	0.1 lux / F2.0	0.1 lux / F2.0
	<b>Field of View:</b>	106.3° horizontal, 67.4° vertical	106.3° horizontal, 67.4° vertical
	<b>Lens:</b>	2.75 mm	2.75 mm
	<b>Frame Rate:</b>	30 fps, MJPEG, H.264	30 fps, MJPEG, H.264
	<b>Streaming:</b>	Dual-stream at different frame rate and bandwidth	Dual-stream at different frame rate and bandwidth
	<b>ONVIF Compliant:</b>	Yes	Yes
<b>Power (Camera Only):</b>	PoE, IEEE 802.3af, Class 3 12VDC 220mA	PoE, IEEE 802.3af, Class 3 12VDC 220mA	

All specifications are subject to change without notice.

## SPECIFICATIONS

### Grandstream IP Video Attendant Phone



<b>Model:</b>	<b>AVM-1 (Grandstream GXV3370): IP Video Attendant Phone</b>
<b>Dimensions (W x H x D):</b>	9.9 x 3.3 x 8.3 in. (252 x 84 x 211 mm)
<b>Weight:</b>	2.38 lbs. (1.08 kg)
<b>Operating Temperature:</b>	32°F to +104°F ( 0°C to 40°C)
<b>Relative Humidity</b>	10% to 90% non-condensing
<b>Mounting:</b>	Wall mountable. Integrated stand with two (2) adjustable angles.
<b>Communication:</b>	6-line IP video phone
<b>Feature Key</b>	Two (2) function keys VOLUME +/-, three (3) dedicated keys for HOME, MENU, and BACK
<b>Protocols/Standards</b>	SIP RFC3261, TCP/IP/UDP, RTP/RTCP, HTTP/HTTPS, ARP, ICMP, DNS (A record, SRV, NAPTR), DHCP, PPPoE, SSH, TFTP, NTP, STUN, SIMPLE, LLDP-MED, LDAP, TR-069, 802.1x, TLS, SRTP
<b>Audio Codecs:</b>	Support for G.711μ/a, G.722 (wide-band), G.726-32, iLBC, Opus, G.729, in-band and out-of-band DTMF (In audio, RFC2833, SIP INFO), VAD, CNG, AEC, PLC, AJB, AGC
<b>Power:</b>	Universal power adapter included: Input 100-240VAC, 50-60Hz; Output 12VDC, 1.5A (18W), supports PoE+ (Power over Ethernet) 802.3at, Class 4
<b>Additional Interface:</b>	RJ9 headset jack (allowing EHS with Plantronics headsets), 3.5mm stereo headset with microphone, dual USB ports, SD, mini-HDMI
<b>Network Interface:</b>	Dual switched 10/100/1000 Mbps ports with integrated PoE
<b>Upgrade/Provisioning:</b>	Firmware upgrade via TFTP/HTTP/HTTPS or local HTTP upload, mass provisioning using TR-069, or AES encrypted XML configuration file
<b>QoS:</b>	Layer 2 QoS (802.1Q, 802.1p) and Layer 3 (ToS, DiffServ, MPLS) QoS
<b>Security:</b>	User and administrator level passwords, MD5 and MD5-sess based authentication, 256-bit AES encrypted configuration file, TLS, SRTP, HTTPS, 802.1x media access control
<b>Wi-Fi:</b>	Dual-band 802.11a/b/g/n (2.4GHz & 5GHz)
<b>Graphic Display:</b>	7-inch (1024x600) capacitive (5-point) touch screen TFT LCD
<b>Scalability:</b>	Supports up to (100) IP Call Stations with Built-in Camera
<b>Compliance:</b>	FCC: Part 15 (CFR 47) Class B; Part68 (HAC) UL: 60950 (power adapter) CE: EN55022 Class B, EN55024, EN61000-3-2, EN61000-3-3, EN60950-1, EN62479, RoHS RCM: AS/ACIF S004; AS/NZS CISPR22/24; AS/NZS 60950; AS/NZS 4268 EAC
<b>Warranty:</b>	2-year limited warranty

All specifications are subject to change without notice.

# SPECIFICATIONS



WaveSense Sensor Switch Specifications

General Specifications	
Operating Temperature:	-4° F to 122° F (-20°C to +50°C) Note: WaveSense-enabled VOIP-200 Series models have this reduced operating temperature range.
Protection:	IP66, vandal-resistant and water-resistant design
Power:	IEEE 802.3at Power over Ethernet (includes PoE splitter for sensor switch and call station). Or sensor switch can be powered separately (12-24VDC, 0.5W max.). For camera-enabled models, separate PoE connection or power supply required for camera (see p.5).
Sensor Switch	
Dimensions:	1.10 in. (28 mm) diameter
Sensor Technology:	Infrared
Gesture Detection Range:	2 in. ±10%

All specifications are subject to change without notice.

# ORDERING INFORMATION

Base Model	Mounting	Verbiage	Camera	WaveSense
VOIP-20	<b>0</b> Flush mount configuration	<b>C</b> "CALL" verbiage	<b>[Leave Blank]</b> No built-in IP camera	<b>[Leave Blank]</b> Tactile pushbutton, no WaveSense sensor
	<b>1</b> Surface mount configuration	<b>H</b> "HELP" verbiage	<b>3</b> Built-in IP camera (requires second Ethernet network connection)	<b>-WAV1</b> Built-in WaveSense sensor replaces tactile push button (this configuration is not currently ETL Listed)
Example	VOIP-20	0	C	-WAV1

Note: WaveSense technology is also available as an add-on device for existing installations of the VOIP-200 Series Compact IP Call Station. For ordering information, see WaveSense datasheet.

All specifications are subject to change without notice.



# DIMENSIONAL DRAWING - VOIP-200C-WAV1

## Flush Mount Version with "CALL" Verbiage and WaveSense Technology

All dimensions are in inches and are provided for reference only.

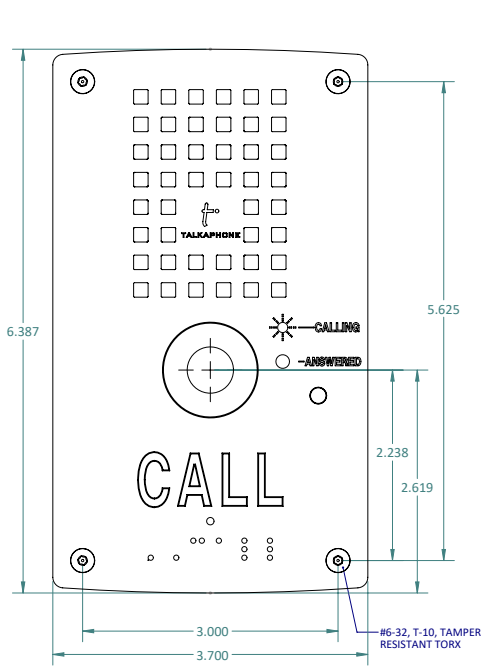

FRONT VIEW

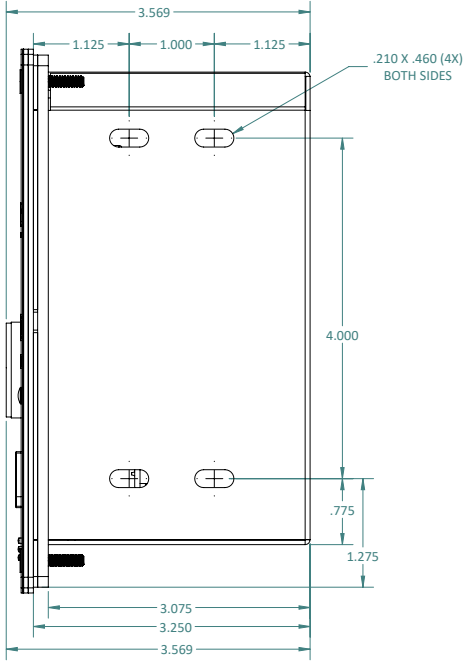

SIDE VIEW

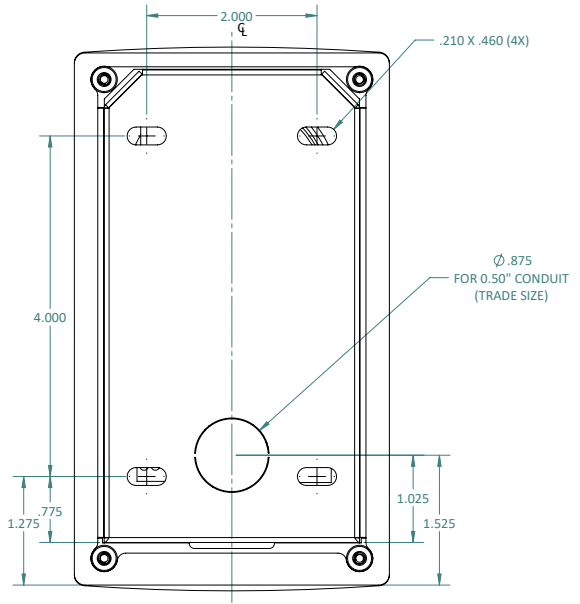

REAR VIEW

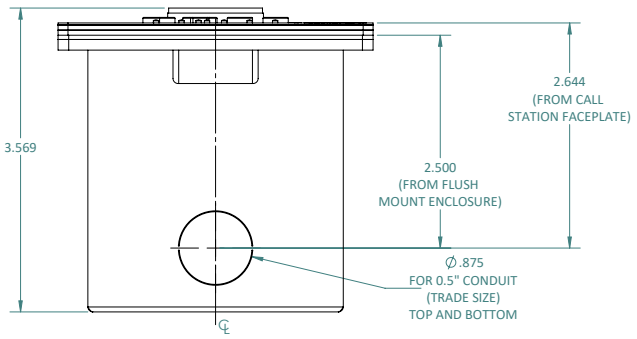

BOTTOM VIEW



# DIMENSIONAL DRAWING – VOIP-201H3

## Surface Mount Version with “HELP” Verbiage and Built-in Camera

All dimensions are in inches and are provided for reference only.

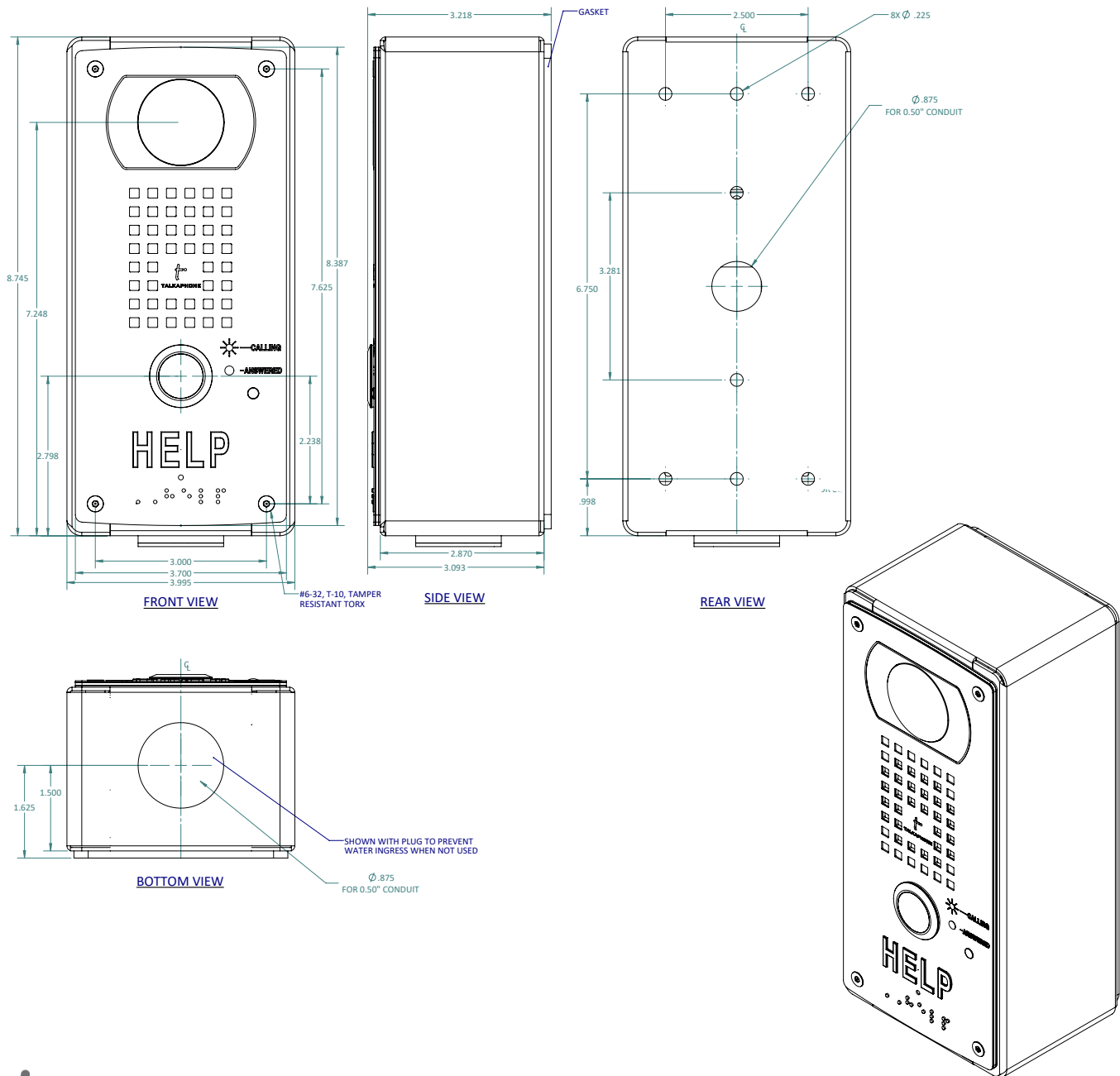

THE LEADERS IN SECURITY AND LIFE SAFETY COMMUNICATIONS

Tel: 773-539-1100  
Email: [info@talkaphone.com](mailto:info@talkaphone.com)  
Web: [www.talkaphone.com](http://www.talkaphone.com)

7530 North Natchez Avenue  
Niles, Illinois 60714

### Terms of Use and Limited Warranty

This Product includes intellectual property and proprietary rights owned by Talk-A-Phone, LLC and/or its licensors. Your use of this Product confirms your agreement that Talk-A-Phone, LLC and/or its licensors retain all right, title and interest in and to all such property; that your rights are to access and use the Product for your internal business use only; that all Product elements will be maintained as confidential; and that the Product may not be rented, leased or lent to third parties, reverse engineered, decompiled or disassembled, or otherwise used for any purpose other than as an access device for your premises.

Talk-A-Phone, LLC warrants Talk-A-Phone Emergency Phone, Call Station, and Wide-Area Emergency Broadcast System equipment against any defects in material and workmanship, under normal use, for a period of twenty-four (24) months from date of installation, provided that Talk-A-Phone receives a completed "Installation Certification" certifying the date on which the system has been installed. An "Installation Certification" card is enclosed with every unit. In the event that no "Installation Certification" is received by Talk-A-Phone, the twenty-four (24) months will commence on the date of shipment by Talk-A-Phone. Warranty period for the metal elements of models in the GP Series Pedestals, MT Series Towers, MTE Series Towers, MT/R Series Towers, PM Series Pedestals, SM Series Surface Mounts, Via Series Mounts, and WM Series Wall Mounts is five (5) years, under the same terms and conditions. Warranty period for Area of Rescue Products is sixty (60) months, under the same terms and conditions. Warranty period for Intercommunication Products is twelve (12) months, under the same terms and conditions. If the Product is found by Talk-A-Phone to be defective within the warranty period, Talk-A-Phone's only obligation, and your exclusive remedy, is for the repair or replacement of any defective parts, provided that the Product is returned to us at 7530 N. Natchez Ave., Niles, IL 60714. Talk-A-Phone shall have no obligation to furnish or pay for the labor of any third parties or bear the expense of shipping defective Products for repair. In no event shall Talk-A-Phone or its licensors or suppliers be liable for any form of exemplary or punitive damages, or any special, indirect or consequential damages. TALK-A-PHONE EXPRESSLY DISCLAIMS ALL OTHER WARRANTIES, WHETHER EXPRESS, IMPLIED OR STATUTORY, INCLUDING BUT NOT LIMITED TO THE IMPLIED WARRANTIES OF MERCHANTABILITY OR FITNESS FOR A PARTICULAR PURPOSE. In no event shall Talk-A-Phone or its licensors or suppliers be liable for any form of exemplary or punitive damages, or any special, indirect or consequential damages. Your use of this Product constitutes your agreement to all of the foregoing terms.

THIS WARRANTY GIVES YOU SPECIFIC LEGAL RIGHTS AND YOU MAY ALSO HAVE OTHER RIGHTS WHICH VARY FROM STATE TO STATE. Further information is available at [talkaphone.com/legal](http://talkaphone.com/legal)

Copyright 2021 Talk-A-Phone, LLC All Rights Reserved - Rev. 01/29/2021